

TECHNICAL MANUAL
ORGANIZATIONAL MAINTENANCE REPAIR PARTS
AND SPECIAL TOOLS LISTS
FOR
RADIO TELETYPEWRITER SET AN/VSC-2
(NSN 5815-00-224-8129)

This copy is a reprint which includes current pages from Change 1.

THIS PUBLICATION IS A COURTESY QUICK COPY FROM THE UNITED STATES ARMY PUBLICATIONS DISTRIBUTION CENTER, ST. LOUIS MISSOURI TO MEET YOUR NEEDS WHILE WE REPLENISH OUR REGULAR STOCK.

HEADQUARTERS, DEPARTMENT OF THE ARMY

SEPTEMBER 1976

CHANGE }
No. 1 }

HEADQUARTERS
DEPARTMENT OF THE ARMY
WASHINGTON, DC., 7 July 1981

**Organizational Maintenance Repair Parts
and Special Tools Lists
for
RADIO TELETYPEWRITER SETS
AN/VSC-2 (NSN 5815-00-224-8129)
AND
AN/VSC-2A (NSN 5815-01-098-2587)**

TM 11-5815-331-20P, 30 September 1976, is changed as follows:

1. Title of the manual is changed as shown above.
2. New or changed material is indicated by a vertical bar.
3. Added or revised illustrations are indicated by a vertical bar before figure number and title.
4. Remove and insert pages as indicated below.

<i>Remove</i>	<i>Insert</i>
i and ii	i and ii
1 and 2.....	1 thru 3
5 and 6.....	5 and 6
None	6.1 and 6.2
15 and 16.....	15 and 16

5. File this change sheet in front of the publication for reference purposes.

By Order of the Secretary of the Army:

E. C. MEYER
General, United States Army
Chief of Staff

Official:

ROBERT M. JOYCE
Brigadier General, United States Army
The Adjutant General

Distribution:

To be distributed in accordance with DA Form 12-51, Organizational maintenance requirements for AN/VSC-2.

TECHNICAL MANUAL

No. 11-5815331-20P



HEADQUARTERS
DEPARTMENT OF THE ARMY
WASHINGTON, DC, 30 September 1976

**ORGANIZATIONAL MAINTENANCE REPAIR PARTS
AND SPECIAL TOOLS LISTS
FOR
RADIO TELETYPEWRITER SETS
AN/VSC-2 (NSN 5815-00-224-8129)
AND
AN/VSC-2A (NSN 5815-01-098-2587)**

Current as of 29 June 1976

REPORTING ERRORS AND RECOMMENDING IMPROVEMENTS
You can help improve this manual. If you find any mistakes or if you know of a way to improve the procedures, please let us know. Mail your letter, DA Form 2028 (Recommended Changes to Publications and Blank Forms), or DA Form 2028-2 located in back of this manual, direct to Commander, US Army Communications and Electronics Materiel Readiness Command, ATTN: DRSEL-ME-MQ, Fort Monmouth, NJ 07703.
In either case, a reply will be furnished direct to you.

Table of Contents

SECTION		Page	Illus Figure
	I. Introduction	1	
	II. Repair parts list	5	
Group	00 Radio Teletypewriter Set AN/VSC-2.....	5	1
	00 Radio Teletypewriter Set AN/VSC-2A	6.1	1A
	01 Radio set AN/GRC-106() (See TM 11-5820-520-25P for parts)		
	02 Modem MD-522()/GRC (See TM 11-5805-387-20P-1, and TM 11-5805387-20P-2 for parts)		
	03 Teletypewriter TT-4C/TG (See TM 11-5815-206-20P for parts or Terminal Communications and UGC-74A(V)3 (See TM 11-5815-602-20P for parts)		
	04 Motor Generator PU-724/G (See TM 11-6125-252-15 for parts)		
	05 Cable assembly, special purpose, electrical, W1 (No parts authorized)		
	06 Cable assembly, special purpose, electrical, W2 (No parts authorized)		
	07 Cable assembly, special purpose, electrical, W3 (No parts authorized)		
	08 Cable assembly, special purpose, electrical, W4 (No parts authorized)		
	09 Cable assembly, special purpose, electrical, W5 (No parts authorized)		
	10 Cable assembly, special purpose, electrical, W6 (No parts authorized)		
	11 Cable assembly, special purpose, electrical, W7 (No parts authorized)		
	12 Cable assembly, special purpose, electrical, W8 (No parts authorized)		
	13 Cable assembly, special purpose, electrical, W9 (No parts authorized)		
	14 Cable assembly, special purpose, electrical, W10 (No parts authorized)		
	15 Cable assembly, special purpose, electrical, W11 (No parts authorized)		
	16 Cable assembly, special purpose, electrical, W12 (No parts authorized)		
	17 Cable assembly, special purpose, electrical, W13 (No parts authorized)		
	18 Cable assembly, special purpose, electrical, W14 (No parts authorized)		
	19 Cable assembly, special purpose, electrical, W15 (No parts authorized)		
	20 Remote box assembly (No parts authorized)		
	21 Control box assembly.....	13	5
	22 Dummy box assembly (No parts authorized)		
	23 Power distribution box	15	6
	24 Control Group AN/GRA-6 (See TM 11-5820-489-20P for parts)		
	25 Antenna Group AN/GRA-50 (See TM 11-5820-467-25P for parts)		

*This manual supersedes TM 11-5815-331-20P 21 August 1968.

	Page
26	Loudspeaker LS-166 (See TM 11-596.5222-14P for parts)
27	Cable assembly, DC power (No parts authorized)
28	Cable assembly, special purpose (No parts authorized)
29	Cable assembly, signal (No parts authorized)
SECTION III.	Special tools list (Not applicable)
IV.	National stock number and part number index..... 16

Change 1 ii

**SECTION I
INTRODUCTION**

1. Scope

This manual lists repair parts and special tools required for performance of organizational maintenance of AN/VSC-2 and AN/VSC-2A.

2. General

This Repair Parts and Special Tools List is divided into the following sections:

a. *Section II-Repair Parts List.* A list of repair parts authorized for use in the performance of maintenance. The list also includes parts which must be removed for replacement of the authorized parts. Parts lists are composed of functional groups in ascending numerical sequence, with the parts in each group listed in figure and item number sequence.

b. *Section III-Special Tools List.* Not applicable.

c. *Section IV-National Stock Number and Part Number Index.* A list, in ascending National item identification number (NIIN, last 9 digits) sequence, of all National stock numbers appearing in the listings, followed by a list, in alphameric sequence, of all part numbers appearing in the listings. National stock number and part numbers are cross-referenced to each illustration figure and item number appearance.

3. Explanation of Columns

The following provides an explanation of columns found in the tabular listings:

a. *Illustration.* This column is divided as follows:

(1) *Figure number.* Indicates the figure number of the illustration in which the item is shown.

(2) *Item number.* The number used to identify each item called out in the illustration.

b. *Source, Maintenance, and Recoverability Codes (SMR).*

(1) *Source code.* Source codes are assigned to support items to indicate the manner of acquiring support items for maintenance, repair, or overhaul of end items. Source codes are entered in the first and second positions of the Uniform SMR Code format as follows:

<i>Code</i>	<i>Definition</i>
PA-	Item procured and stocked for anticipated or known usage.
PD-	Support item, excluding support equipment, procured for initial issue or outfitting and stocked only for subsequent or additional initial issues or outfittings. Not subject to automatic replenishment.
XD-	A support item that is not stocked. When required, item will be procured through normal supply channels.

NOTE

Cannibalization or salvage may be used as a source of supply for any items source coded above except those coded XA, XD, and aircraft support items as restricted by AR 700-42.

(2) *Maintenance code.* Maintenance codes are assigned to indicate the levels of maintenance authorized to USE and REPAIR support items. The maintenance codes are entered in the third and fourth positions of the Uniform SMR Code format as follows:

(a) The maintenance code entered in the third position will indicate the lowest maintenance level authorized to remove, replace, and use the support item. The maintenance code entered in the third position will indicate one of the following levels of maintenance:

<i>Code</i>	<i>Application/Explanation</i>
O-	Support item is removed, replaced, used at the organizational level.

(b) The maintenance code entered in the fourth position indicates whether the item is to be repaired and identifies the lowest maintenance level with the capability to perform complete repair (i.e., all authorized maintenance functions). This position will contain one of the following maintenance codes:

<i>Code</i>	<i>Application/Explanation</i>
F-	The lowest maintenance level capable of complete repair of the support item is the direct support level.
H-	The lowest maintenance level capable of complete repair of the support item is the general support level.
D-	The lowest maintenance level capable of complete repair of the support item is the depot level.
Z-	Nonreparable. No repair is authorized.

(3) *Recoverability code.* Recoverability codes are assigned to support items to indicate the disposition action on unserviceable items. The recoverability code is entered in the fifth position of the Uniform SMR Code format as follows:

<i>Recoverability codes</i>	<i>Definition</i>
Z-	Nonreparable item. When unserviceable, condemn and dispose at the level indicated in position 3.
F-	Reparable item, When uneconomically reparable, condemn and dispose at the direct support level.
H-	Reparable item. When uneconomically reparable, condemn and dispose at the general support level.

Recoverability codes

Definition

- D- Repairable item. When beyond lower level repair capability, return to depot. Condemnation and disposal not authorized below depot level.
- L- Repairable item. Repair, condemnation, and disposal not authorized below depot/specialized repair activity level.

c. *National Stock Number.* Indicates the National stock number assigned to the item and will be used for requisitioning purposes.

d. *Part Number.* Indicates the primary number used by the manufacturer (individual, company, firm, corporation, or Government activity), which controls the design and characteristics of the item by means of its engineering drawings, specifications standards, and inspection requirements, to identify an item or range of items.

NOTE

When a stock numbered item is requisitioned, the repair part received may have a different part number than the part being replaced.

e. *Federal Supply Code for Manufacturer (FSCM).* The FSCM is a 5-digit numeric code listed in SB 708-41/42 which is used to identify the manufacturer, distributor, or Government agency, etc.

f. *Description.* Indicates the Federal item name and, if required, a minimum description to identify the item.

g. *Unit of Measure (U/M).* Indicates the standard of the basic quantity of the listed item as used in performing the actual maintenance function. This measure is expressed by a two-character alphabetical abbreviation (e.g., ea, in, pr, etc.). When the unit of measure differs from the unit of issue, the lowest unit of issue that will satisfy the required units of measure will be requisitioned.

h. *Quantity Incorporated in Unit.* Indicates the quantity of the item used in the breakout shown on the illustration figure, which is prepared for a functional group, subfunctional group, or an assembly.

4. Special Information

a. Usable on codes are shown in the description column. Uncoded items are applicable to all models. Identification of the usable on codes used in this publication are:

<i>Code</i>	<i>Used on</i>
No code	AN/VSC-2
EHA	AN/VSC-2A

b. The following publications pertain to the AN/VSC-2 and AN/VSC-2A and its components:

- TM 11-5038, Control Group AN/GRA-6
- TM 11-5805-387-15-1, Modem, Radio Teletypewriter MD-522/GRC
- TM 11-5805-387-15-2, Radio Teletypewriter Modem MD-522A/GRC
- TM 11-5805-387-20P-2, Modem, Radio Teletypewriter MD-522A/GRC
- TM 11-5805-387-24P-1, Modem, Radio Teletypewriter MD-522/GRC
- TM 11-5815-206-12, Teletypewriter Sets AN/PGC-1 and AN/PGC-3 and Teletypewriters TT-4A/TG, TT-4B/TG, TT-4C/TG, TT-335/TG, TT-537/TG, TT-698/TG, TT-698A/TG, TT-698B/TG, TT-722/TG and TT-722A/TG
- TM 11-5815-206-20P, Teletypewriter Sets AN/PGC-1 and AN/PGC-3 and Teletypewriters TT-4A/TG, TT-4B/TG, TT-4C/TG, TT-335/TG, TT-537/TG, TT-698/TG, TT-698A/TG, TT-698B/TG, TT-722/TG and TT-722A/TG
- TM 11-5815-331-14, Radio Teletypewriter Sets AN/VSC-2 and AN/VSC-2A
- TM 11-5815-602-12, Terminal, Communications AN/UGC-74A(V)3
- TM 11-5815-602-20P, Terminal, Communications AN/UGC-74A(V)3
- TM 11-5810-467-15, Antenna Group AN/GRA-50 (to be published).
- TM 11-5810-467-24P, Antenna Group AN/GRA-50 (to be published).
- TM 11-5820-48920P, Control Group AN/GRA-6
- TM 11-5820-520-12, Radio Sets AN/GRC-106 and AN/GRC-106A
- TM 11-5820-520-20P-1, Radio Set AN/GRC-106
- TM 11-5820-520-20P-2, Radio Set AN/GRC-106A
- TM 11-5965222-14P, Dynamic Loudspeaker LS-166/U
- TM 11-6125-252-15, Motor-Generator PU-724/G

c. The illustrations in this manual are identical to those published in TM 11-5815-331-34P. Only those parts assigned the third position SMR maintenance code "C" or "O" are listed in the tabular listing; therefore, there may be a break in the item number sequence. Only illustrations containing organizational authorized items appear in this manual.

d. National stock numbers (NSN's) that are missing from P source coded items have been applied for and will be added to this TM by future change/revision when they are entered in the Army Master Data File (AMDF). Until the NSN's are established and published, submit exception requisitions to Commander, US Army Communications and Electronics Materiel Readiness Command, ATTN: DRSEL-MM, Fort Monmouth, NJ 07703 for the part required to support your equipment.

e. Action change codes indicated in the left-hand margin of the listing page denote the following:

- N-Indicates an added item.
- C-Indicates a change in data.
- R-Indicates a change in NSN only.

5. How to Locate Repair Parts

a. When National stock number or part number is unknown.

(1) *First.* Using the table of contents, determine the functional group within which the repair part belongs. This is necessary since illustrations are prepared for functional groups and listings are divided into the same groups.

(2) *Second.* Find the illustration covering the functional group to which the repair part belongs.

(3) *Third.* Identify the repair part on the illustration and note the illustration figure and item number of the repair part.

(4) *Fourth.* Using the Repair Parts Listing, find the figure and item number noted on the illustration.

b. When National stock number or part number is known.

(1) *First.* Using the Index of National Stock Numbers and Part Numbers, find the pertinent National stock number or part number. This index is in ascending NIIN sequence followed by a list of part numbers in ascending alphameric sequence, cross-referenced to the illustration figure number and item number.

(2) *Second.* After finding the figure and item number, locate the figure and item number in the repair parts list.

6. Abbreviations

Not applicable.

(Next printed page is 4)

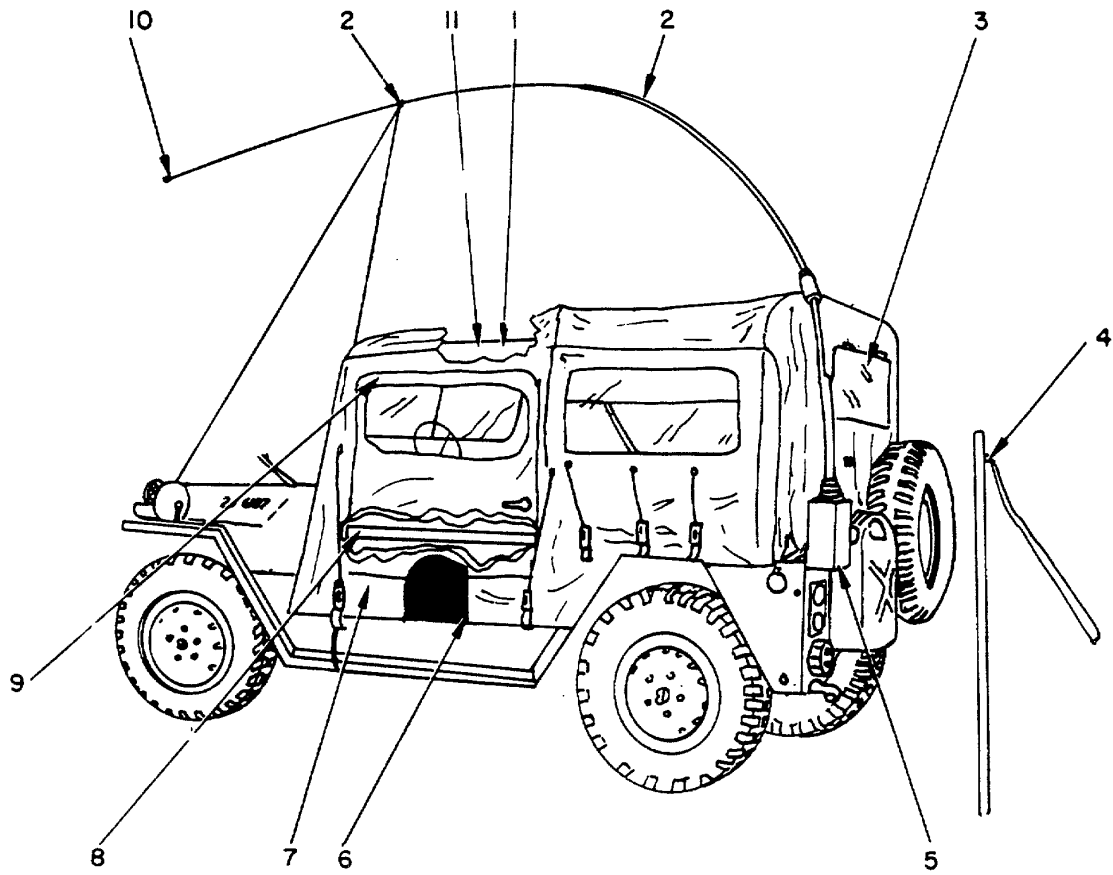

EL2KS001

Figure 1. Radio Teletypewriter Set AN/VSC-2.

SECTION II

TM 11-5815-331-20P

(1)		(2)	(3)	(4)	(5)	(6)	(7)	(8)
ILLUSTRATION		SMR CODE	NATIONAL STOCK NUMBER	PART NUMBER	FSCM	DESCRIPTION <i>USABLE ON CODE</i>	U/M	QTY INC IN UNIT
(a) FIG NO.	(b) ITEM NO.							
						GROUP 00 RADIO TELETYPEWRITER SET		
						ANVSC-2		
1	1	PAOZZ	25A0-00-472-1669	7345097	80212	CURTAIN, VEHICLE, RIGHT DOOR.....	EA	1
1	2	PAOZZ	5340-00-568-9912	HOLD ALL NO. 36	52562	CLAMP SPRING.....	EA	2
1	3	XDOZZ		7345090	80212	CURTAIN ASSEMBLY.....	EA	1
1	4	PAOZZ	5820-00-930-1999	SCC446047	80063	GROUND ROD AND STRAP ASSEMBLY.....	EA	1
1	5	PAOZZ	5820-00-045-9696	SCDS2096	80063	ANTENNA MOUNT ASSEMBLY.....	EA	1
1	6	PAOZZ	4130-00-814-9179	E10-365C	95347	FILTER.....	EA	1
1	7	PAOHD	2510-00-789-0067	7331243	80212	DOOR FRAME ASSELY, LEFT HAND.....	EA	1
1	8	XDOZZ		7331287	80212	ROD, CENTER POST.....	EA	1
1	9	PAOZZ	2540-00-472-1670	7345100	80212	CURTAIN, VEHICLE, LEFT DOOR.....	EA	1
1	10	PAOZZ	5985-00-930-7223	SCC446046	80063	ANTENNA TIP ASSEMBLY.....	EA	1
1	11	PAOHD	2510-00-789-0068	7331229	80212	DOOR FRAME ASSEMBLY, RIGHT HAND.....	EA	1

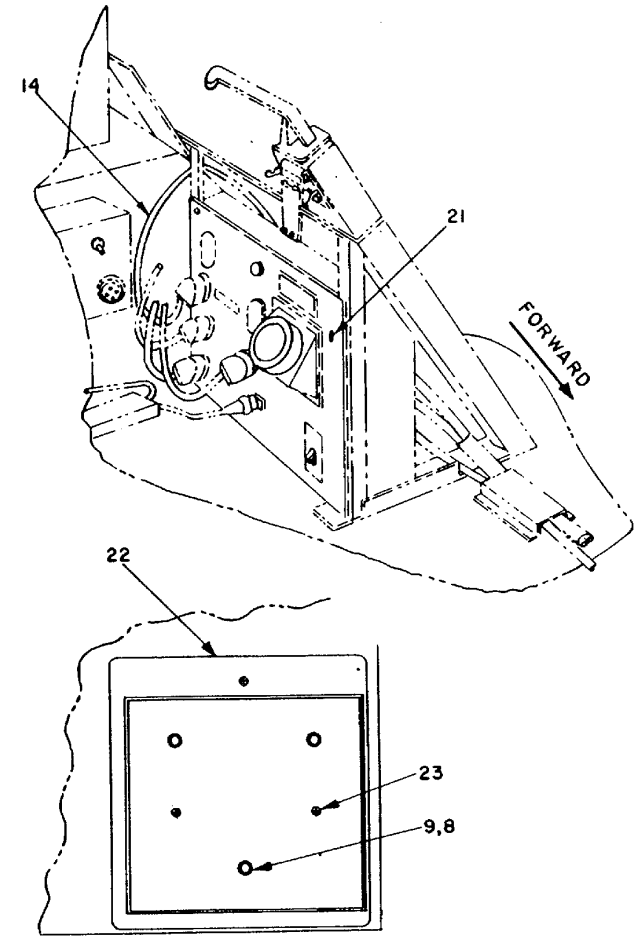
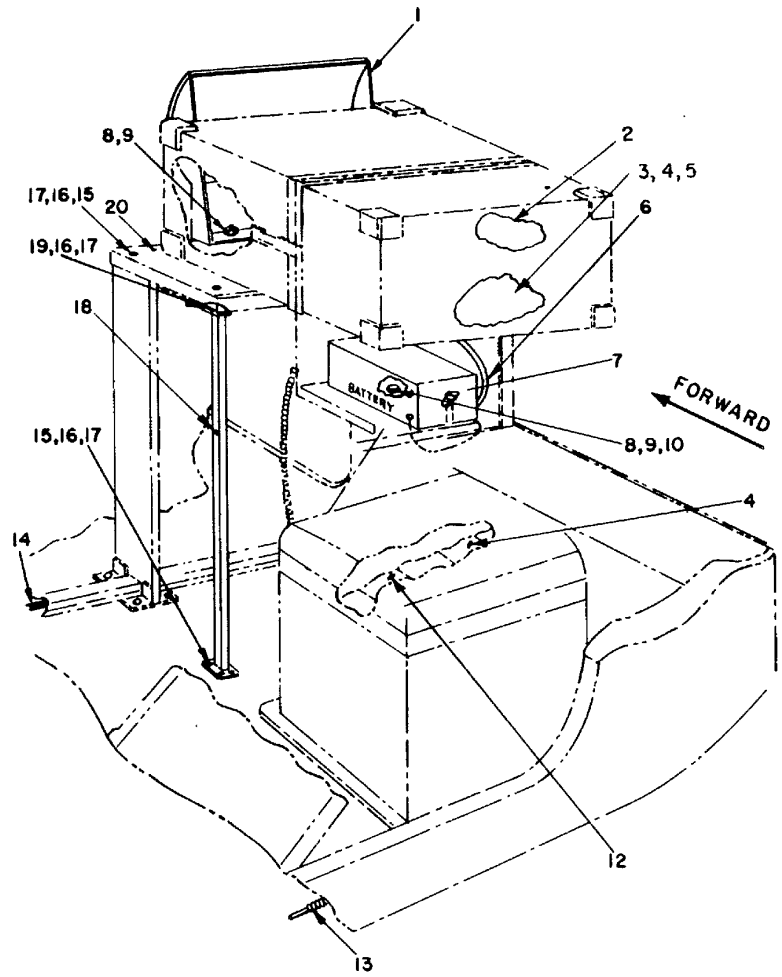

EL2KS007

Figure 1A. Radio Teletypewriter Set AN/VSC-2A.

SECTION II

TM 11-5815-331-20P

	(1)		(2)	(3)	(4)	(5)	(6)	(7)	(8)
	ILLUSTRATION		SMR CODE	NATIONAL STOCK NUMBER	PART NUMBER	FSCM	DESCRIPTION <i>USABLE ON CODE</i>	U/M	QTY INC IN UNIT
(a) FIG NO.	(b) ITEM NO.								
N	1A	2	PDOHH		ANUGC-74A	80058	GROUP 00 RADIO TELETYPEWRITER SET ANVSC-2A TERMINAL, COMMUNICATIONS..... EHA	EA	1
N	1A	6	PAOFF		SC-D-960025-2	80063	CABLE ASSEMBLY, SPECIAL PURPOSE..... EHA	EA	1
N	1A	13	PAOFF		SC-D-972487	80063	CABLE ASSEMBLY, SIGNAL..... EHA	EA	1
N	1A	14	PAOFF		SC-D-658761	80063	CABLE ASSEMBLY, DC POWER..... EHA	EA	1

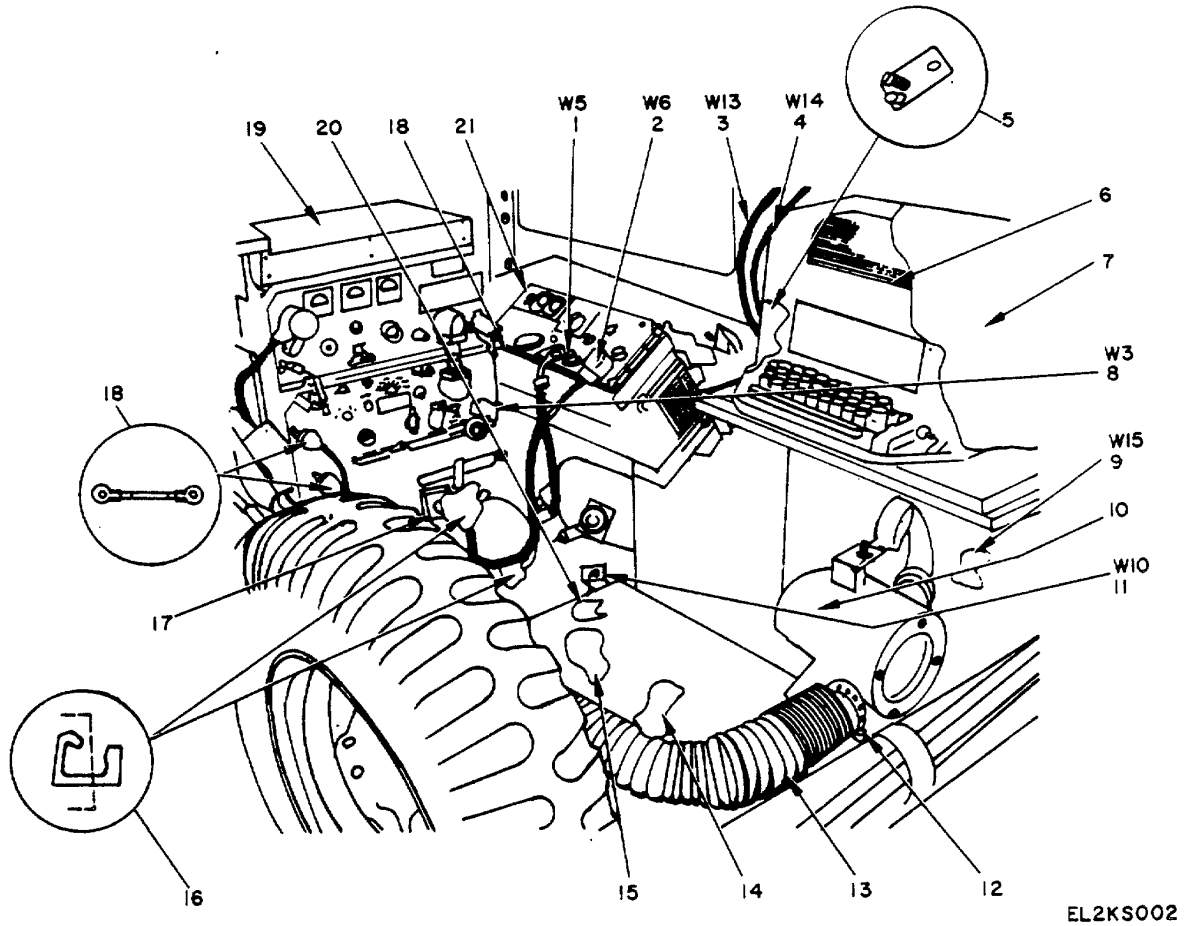

EL2KS002

Figure 2. Radio Teletypewriter Set AN/VSC-2 (Rear Curbside View).

SECTION II

TM 11-5815-331-20P

(1)		(2)	(3)	(4)	(5)	(6)	(7)	(8)
ILLUSTRATION		SMR CODE	NATIONAL STOCK NUMBER	PART NUMBER	FSCM	DESCRIPTION <i>USABLE ON CODE</i>	U/M	QTY INC IN UNIT
(a) FIG NO.	(b) ITEM NO.							
2	1	PAOHH	5995-00-930-6675	SCD446022	80063	CABLE ASSEMBLY, SPECIAL PURPOSE, ELECTRICAL	EA	1
2	2	PAOHH	5995-00-930-6672	SCD446030	80063	CABLE ASSEMBLY, SPECIAL PURPOSE, ELECTRICAL	EA	1
2	3	PAOHH	5995-00-494-6674	SCD446243	80063	CABLE ASSEMBLY, SPECIAL PURPOSE, ELECTRICAL	EA	1
2	4	PAOHH	5995-00-762-4952	SCD446244	80063	CABLE ASSEMBLY, SPECIAL PURPOSE, ELECTRICAL	EA	1
2	5	PAOZZ	5995-00-089-0461	LBADD13768	21617	BINDING POST ASSEMBLY	EA	4
2	6	PDOHH	5815-00-198-4438	TT4CTG	80058	TELETYPEWRITER	EA	1
2	7			SCB460D48	80063	COVER, TELETYPEWRITER	EA	1
2	8	PAOHH	5995-00-089-0463	LBADD13776	21617	CABLE ASSEMBLY, SPECIAL PURPOSE, ELECTRICAL	EA	1
2	9	XDOZZ		SCC446245	80063	CABLE ASSEMBLY, SPECIAL PURPOSE, ELECTRICAL	EA	1
2	10	PDOHD	6125-00-617-1435	SS688	96906	MOTOR, GENERATOR	EA	1
2	11	PAOHH	5995-00-933-5962	SCD446021	80063	CABLE ASSEMBLY, SPECIAL PURPOSE, ELECTRICAL	EA	1
2	12	PAOZZ	4730-00-908-6292	MS35842-14	96906	CLAMP AIR HOSE	EA	2
2	13	XDOZZ		7986299	80212	HOSE, AIR DUCK	EA	1
2	14	XDOFD		SCD446011	80063	REMOTE BOX ASSEMBLY	EA	1
2	15			SCD440049	80063	COVER, SECURITY	EA	1
2	16			SCC208061	80063	SECURITY CLAMP AND THUMB SCREW ASSEMBLY	EA	2
2	17	XDOFD		SCD446034	80063	CONTROL BOX ASSEMBLY	EA	1
2	18	PAOZZ	5970-00-933-6489	SCC446076	80063	GROUND STRAP ASSY	EA	2
2	19	PDOHD	5820-00-082-3491	ANGRC106	80058	RADIO SET	EA	1
2	20	XDOZZ		LBAD813771	21617	JUMPER CABLE ASSEMBLY	EA	1
2	21	PDOHD	5815-00-999-5277	MD522GRC	80058	MODEM	EA	1

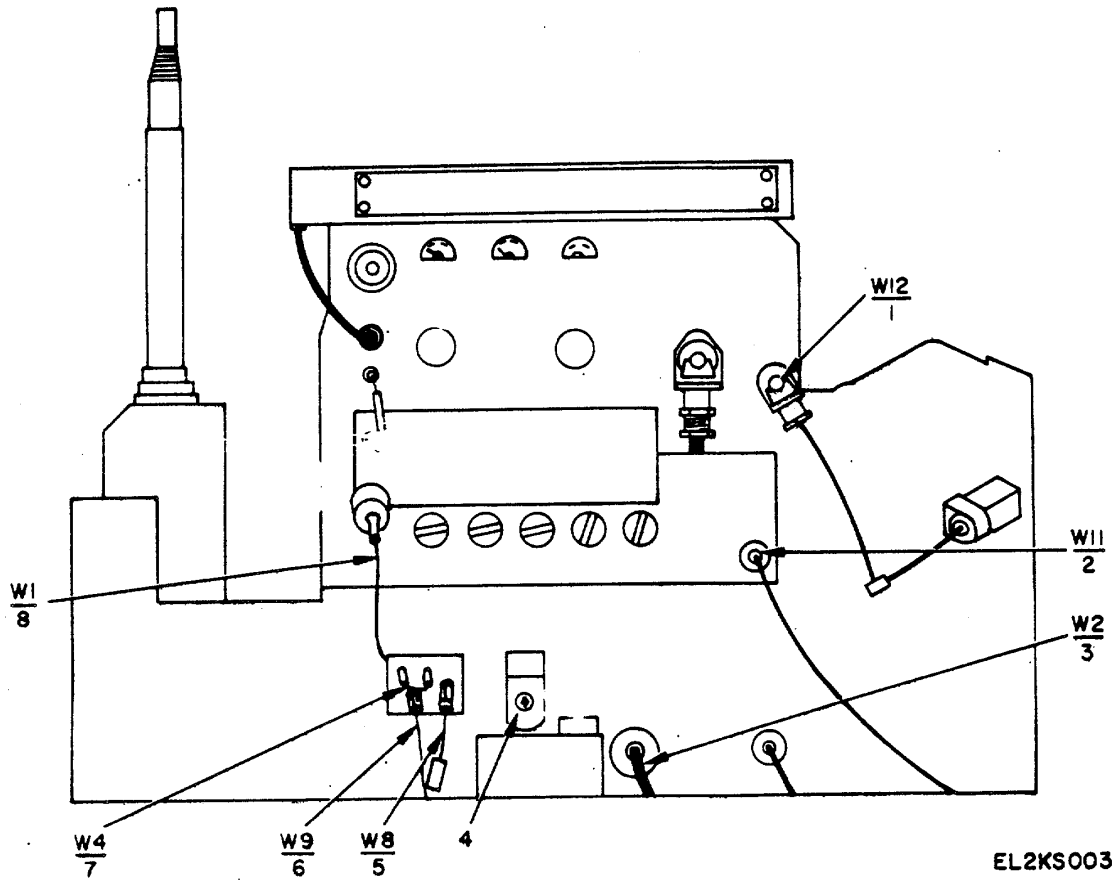
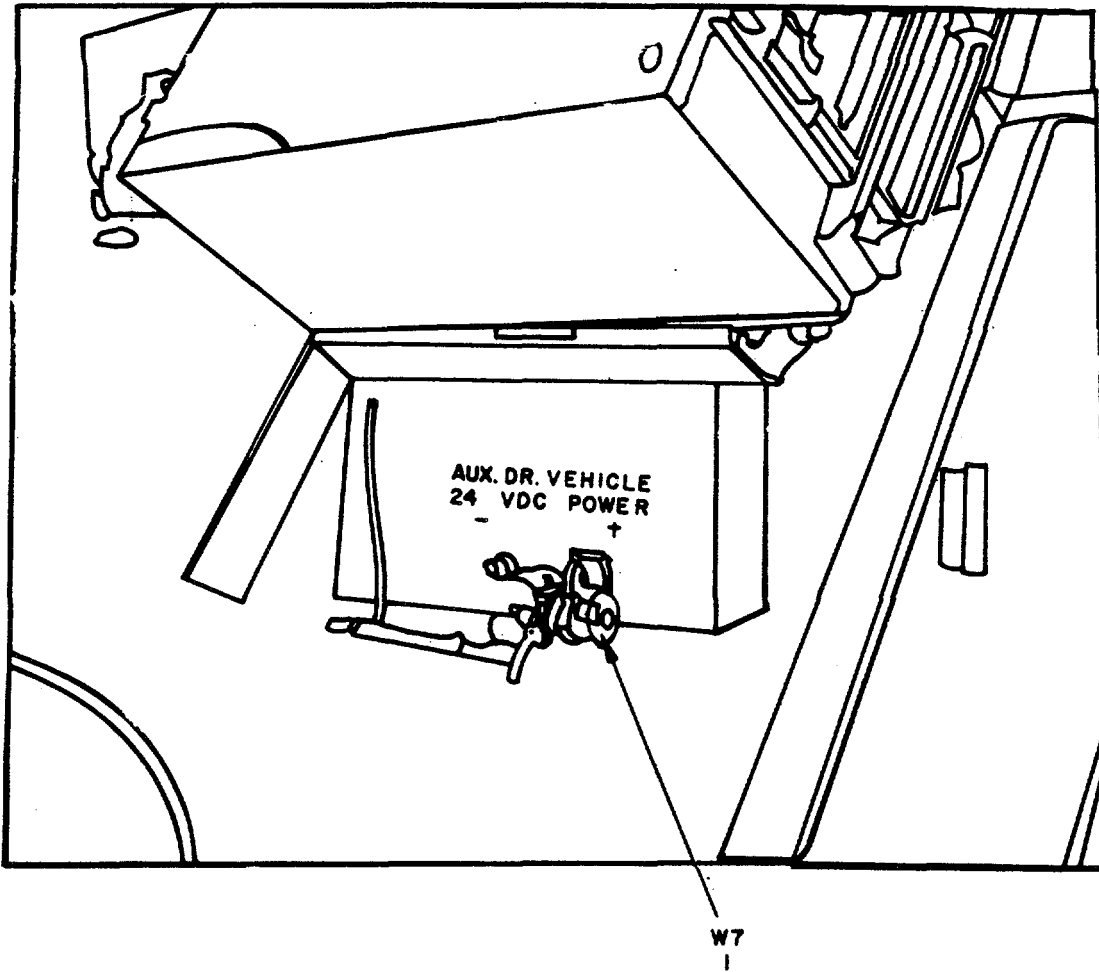

Figure 3. Radio Teletypewriter Set AN/VSC-2 (Location of Cables).

SECTION II

TM 11-5815-331-20P

(1)		(2)	(3)	(4)	(5)	(6)	(7)	(8)
ILLUSTRATION		SMR CODE	NATIONAL STOCK NUMBER	PART NUMBER	FSCM	DESCRIPTION <i>USABLE ON CODE</i>	U/M	QTY INC IN UNIT
(a) FIG NO.	(b) ITEM NO.							
3	1	PAOHH	5995-00-933-5793	SCD460303	80063	CABLE ASSEMBLY, SPECIAL PURPOSE, ELECTRICAL	EA	1
3	2	PAOHH	5995-00-930-5792	SCD4A60302	8063	CABLE ASSEMBLY, SPECIAL PURPOSE, ELECTRICAL	EA	11
1	3	PAOHH	5995-00-933-5794	SCD446035	80063	CABLE ASSEMBLY, SPECIAL, ELECTRICAL	EA	1
3	4	XDOZZ		LBADD013772	21617	SPEAKER MOUNTING BRACKET AND CLAMP ASSEMBLY	EA	1
3	5	PAOHH	5995-00-930-7536	SC444607	80063	CABLE ASSEMBLY, SPECIAL PURPOSE, ELECTRICAL	EA	1
3	6	XDOHH		SCC446073	60063	CABLE ASSEMBLY, SPECIAL PURPOSE, ELECTRICAL	EA	1
3	7	PAOHH	5995-00-930-6678	SCD446037	80063	CABLE ASSEMBLY, SPECIAL ASSEMBLY	EA	1
3	8	PAOHH	5995-00-937-8997	SCD446054	860063	CABLE ASSEMBLY, SPECIAL PURPOSE, ELECTRICAL	EA	1



EL2KS00

Figure 4. Radio Teletypewriter Set AN/VSC-2 (Curbside View, Seat Removed).

SECTION II

TM 11-5815-331-20P

(1)		(2)	(3)	(4)	(5)	(6)	(7)	(8)
ILLUSTRATION		SMR CODE	NATIONAL STOCK NUMBER	PART NUMBER	FSCM	DESCRIPTION <i>USABLE ON CODE</i>	U/M	QTY INC IN UNIT
(a) FIG NO.	(b) ITEM NO.							
	1	PAOHH	5995-00-930-6676	SCD208739	80063	CABLE ASSEMBLY, SPECIAL PURPOSE, ELECTRICAL	EA	1

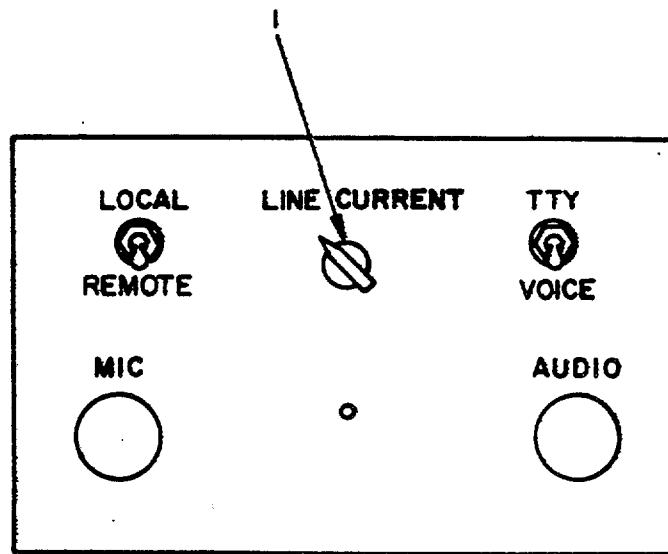

EL2KS005

Figure 5. Control Box Assembly.

SECTION II

TM 11-5815-331-20P

(1)		(2)	(3)	(4)	(5)	(6)	(7)	(8)
ILLUSTRATION		SMR CODE	NATIONAL STOCK NUMBER	PART NUMBER	FSCM	DESCRIPTION <i>USABLE ON CODE</i>	U/M	QTY INC IN UNIT
(a) FIG NO.	(b) ITEM NO.							
5	1	PAOZZ	5355-00-160-6096	SCD105817	80063	KNOB.....	EA	1

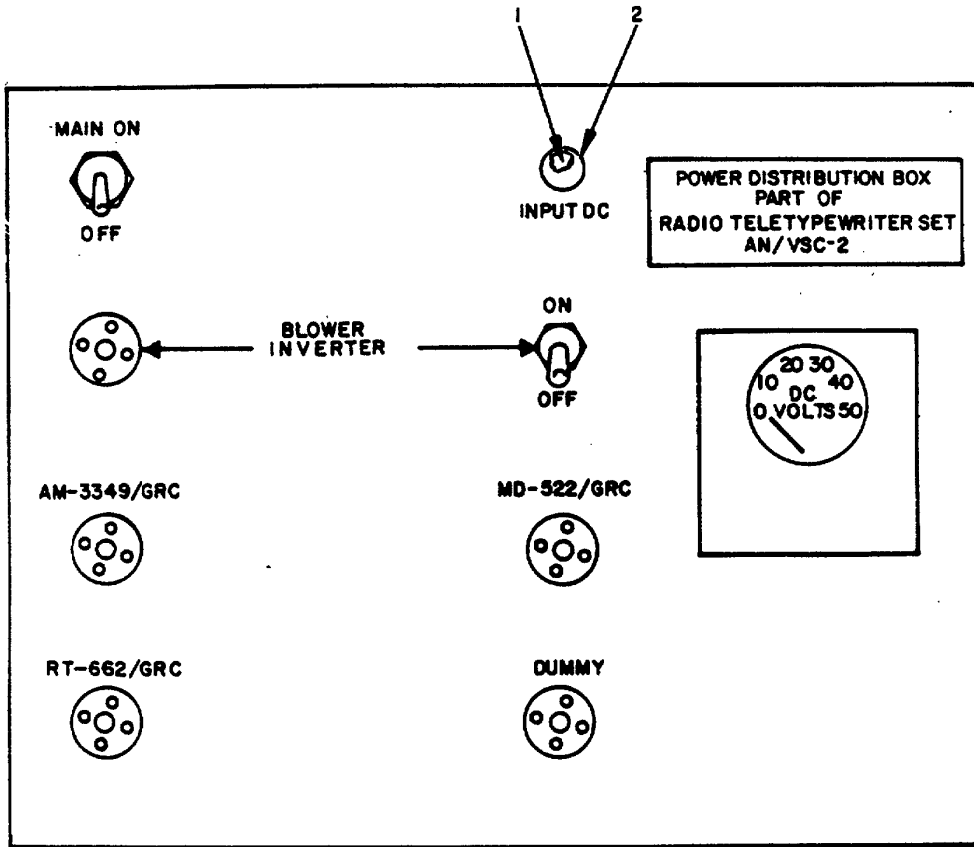

EL2K9006

Figure 6. Power Distribution Box.

SECTION II

TM 11-5815-331-20P

(1)		(2)	(3)	(4)	(5)	(6)	(7)	(8)
ILLUSTRATION		SMR CODE	NATIONAL STOCK NUMBER	PART NUMBER	FSCM	DESCRIPTION <i>USABLE ON CODE</i>	U/M	QTY INC IN UNIT
(a) FIG NO.	(b) ITEM NO.							
6	1	PAOZZ	6210-00-682-9833	MS525256-6	96906	GROUP 23 POWER DISTRIBUTION BOX LAMP, INDICATOR.....	EA	1
6	2	PAOZZ	6240-00-155-7836	MS25237-327	96906	LAMP, INCANDESCENT.....	EA	1

SECTION IV

TM 11-5815-331-20P

NATIONAL STOCK NUMBER AND PART NUMBER INDEX

NOTE: LATEST NATIONAL STOCK NUMBER AND PART NUMBER ASSIGNMENTS ARE INCLUDED AT END OF INDEX

STOCK NUMBER	FIGURE NO.	ITEM NO.	STOCK NUMBER	FIGURE NO.	ITEM NO.
5820-00-045-9696	1	5	4730-00-908-6292	2	12
5940-00-089-0461	2	5	5820-00-930-1999	1	4
5995-00-089-0463	2	8	5995-00-933-5794	3	3
5355-00-160-6096	5	1	5995-00-933-5962	2	11
5815-00-198-4438	2	6	5975-00-933-6489	2	18
6210-00-682-9833	6	1	5815-00-999-5277	2	21

PART NUMBER	FSCM	FIGURE NO.	ITEM NO.	PART NUMBER	FSCM	FIGURE NO.	ITEM NO.
ANGRC106	80058	2	19	SCD446022	80063	2	1
				SCD446030	80063	2	2
				SCD4460302-6	80063	3	2
LBADB13771	21617	2	20	SCD4460303-0	80063	3	1
LBADD13768	21617	2	5	SCD446034	80063	2	17
LBADD13772	21617	3	4	SCD446035	80063	3	3
LBADD13776	21617	2	8	SCD446037	80063	3	7
MD522GRC	80058	2	21	SCD446054	80063	3	8
MS25256-6	96906	6	1	SCD446243	80063	2	3
MS35842-14	96906	2	12	SCD446244	80063	2	4
SCB105817	80063	5	1	SCD52096	80063	1	5
SCB446048	80063	2	7	SS688	66099	2	10
SCC446046	80063	1	10	TT4CTG	80058	2	6
SCC446047	80063	1	4				
SCC446073	80063	3	6				
SCC446074	80063	3	5	7331229	80212	1	11
SCC446076	80063	2	18	7331243	80212	1	7
SCC446245	80063	2	9	7331287	80212	1	8
SCD208739	80063	4	1	7345090	80212	1	3
SCD440049	80063	2	15	7345097	80212	1	1
SCD446011	80063	2	14	7345100	80212	1	9
SCD446021	80063	2	11	7986299	80212	2	13

LATEST NATIONAL STOCK NUMBER ASSIGNMENTS

ADDITIONAL LATEST PART NUMBER ASSIGNMENTS

STOCK NUMBER	FIGURE NO.	ITEM NO.	PART NUMBER	FSCM	FIGURE NO.	ITEM NO.
5820-00-082-3491		2	AN/UGC-74A	80058	1A	2
2540-00-472-1669		1	SC-D-658761	80063	1A	14
2540-00-472-1670		1	SC-D-960025-2	80063	1A	6
5340-00-568-9912		1	SC-D-972487	80063	1A	L3
6125-00-617-1435		2				
2510-00-789-0067		1				
2510-00-789-0068		1				
4130-00-841-9179		1				
5995-00-930-7536		3				
5995-00-930-6672		2				
5995-00-930-6675		2				
5995-00-930-6676		4				
5995-00-930-6678		3				
5985-00-930-7223		1				
5995-00-933-5792		3				
5995-00-933-5793		3				
5995-00-937-8997		3				

LATEST PART NUMBER ASSIGNMENTS

PART NUMBER	FSCM	FIGURE NO.	ITEM NO.
E10-365C	95347	1	6
HOLD ALL NO. 36	52562	1	2
MS25237-327	96906	6	2
SCC208061	80063	2	16

ADDITIONAL LATEST NATIONAL STOCK NUMBER ASSIGNMENTS

STOCK NUMBER	FIGURE NO.	ITEM NO.
6240-00-155-7836	6	2
2540-00-472-1669	1	1
2540-00-472-1670	1	9
5995-00-494-6674	2	3
5995-00-762-4952	2	4
5995-00-930-5792	3	2
5995-00-933-5793	3	1

By Order of the Secretary of the Army:

FRED C. WEYAND
General, United States Army
Chief of Staff

Official:

PAUL T. SMITH
Major General, United States Army
The Adjutant General

Distribution:

To be distributed in accordance with DA Form 12-51, Organizational TMP literature requirements for AN/VSC-2.

☆U.S. GOVERNMENT PRINTING OFFICE: 1984 0-461-202(11249)

RECOMMENDED CHANGES TO EQUIPMENT TECHNICAL PUBLICATIONS



THEN...JOT DOWN THE DOPE ABOUT IT ON THIS FORM. CAREFULLY TEAR IT OUT, FOLD IT AND DROP IT IN THE MAIL.

SOMETHING WRONG WITH PUBLICATION

FROM: (PRINT YOUR UNIT'S COMPLETE ADDRESS)

DATE SENT

PUBLICATION NUMBER

PUBLICATION DATE

PUBLICATION TITLE

BE EXACT PIN-POINT WHERE IT IS

PAGE NO.	PARA-GRAPH	FIGURE NO.	TABLE NO.
----------	------------	------------	-----------

IN THIS SPACE, TELL WHAT IS WRONG AND WHAT SHOULD BE DONE ABOUT IT.

TEAR ALONG PERFORATED LINE

PRINTED NAME, GRADE OR TITLE AND TELEPHONE NUMBER

SIGN HERE

